

UNITED MOTORS SERVICE CORP. MODELS R-1227, R-1228, (DIV. OF GEN. MOTORS) R-1229

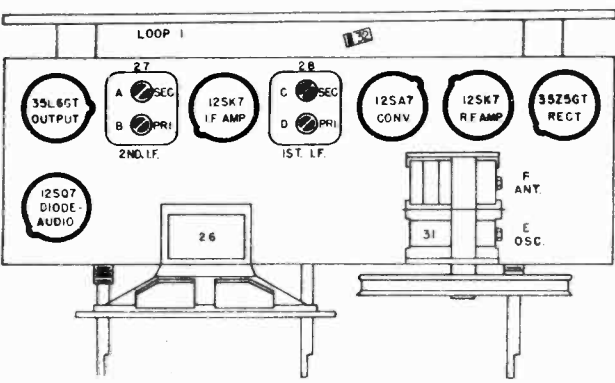

PARTS LAYOUT — TUBE VIEW
TRIMMERS ON SIDE OF TUNING CONDENSER

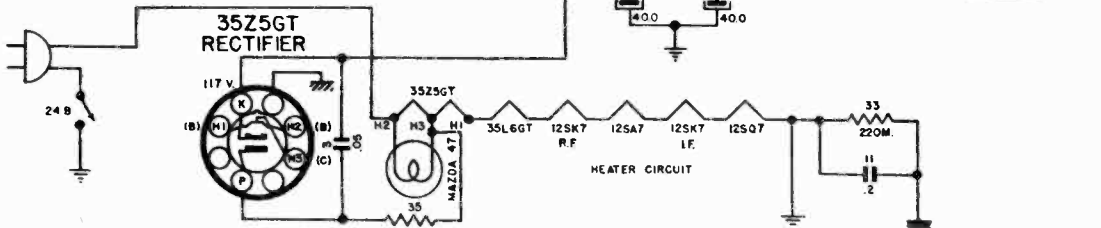
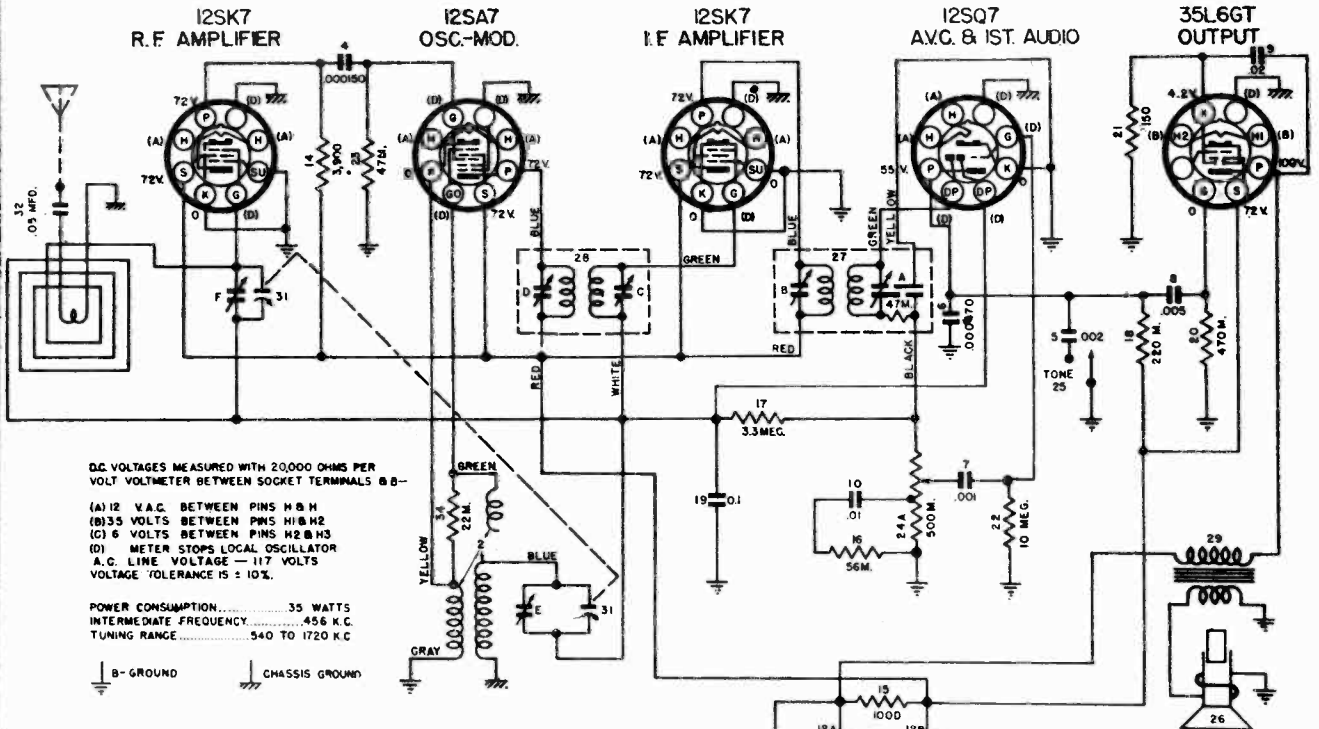
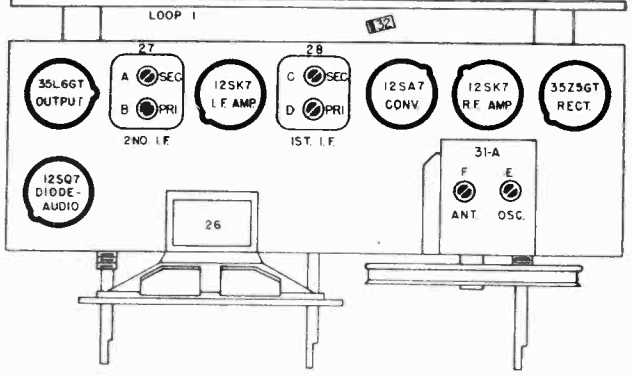

PARTS LAYOUT — TUBE VIEW
TRIMMERS ON TOP OF TUNING CONDENSER

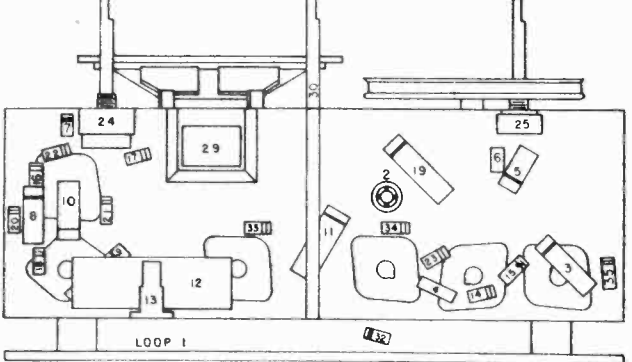
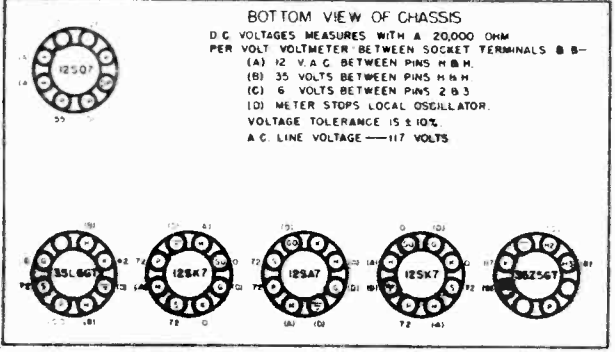

PARTS LAYOUT — CHASSIS VIEW